

# VICON VICONNET



## ViconNet Shadow Elite Workstation

Best-in-class Workstation to streamline operations and deliver effective security for your ViconNet system

Powered by Dell and Intel Technology



### Summary

The ViconNet Shadow Elite Workstation unites reliability, performance and convenience to reduce system ownership costs, streamline operations and deliver more effective security for your ViconNet system. With top-of-the-line Dell components, this server gives you confidence that your system will perform even in the most challenging installations. Available in a small tower form factor, it adapts seamlessly to your surveillance operation.

### Product at a Glance

- ▶ Available as SFF desktop server
- ▶ Install quickly with ViconNet pre-installed
- ▶ Powered by best-in-class Dell and Intel technology
- ▶ Offers peace of mind with 5-year warranty with next business day, on-site support
- ▶ Safeguard your system with SafeBIOS, SafeID, TPM 2.0



#### Powered by Dell & Intel for Machines that Last

- Top-of-the-line components ensure long-lasting performance
- Future-proof your operation with the latest-gen technology



#### Installs in Minutes with Preloaded ViconNet Software

- ViconNet software preloaded for installation in minutes



#### Backed by a 5-Year Warranty and 24/7 Support

- Includes next business day on-site support
- Covers all components (including HDD)

Model	Small Form Factor NEWA-SF000D
Operating System:	Microsoft® Windows® 11† Enterprise IoT LTSC
CPU/RAM:	Intel® Core® Ultra 5, 8 GB DDR5
OS Drive:	1x 256 GB SSD
Max. Supported Data Drives:	1x 3.5" max
Data Drives Configuration:	SATA
Networking:	2x 1GbE RJ-45
Video:	Intel HD (3x DP*; 1x HDMI); supports quad 4K monitors
Additional Rear Panel I/O:	4x USB 3.2 + 2x USB 2.0
Front Panel I/O:	1x USB 3.2 Type C + 1x USB 3.2 + 2x USB 2.0; 1x Headphone
Electrical	
Power Supply:	300 W
Typical Power Consumption:	200 W (650 BTU)
Max. Power Consumption:	300 W (1000 BTU)
Mechanical	
Application:	Indoor
Mounting:	Desktop
Dimensions (HxWxD):	11.95 in. (303.5 mm) x 3.74 in. (95.0 mm) x 11.54 in. (293.0 mm)
Weight:	14.51 lb (6.58 kg)
Construction:	Steel and plastic
Environmental	
Operating Temperature:	50° to 113°F (10° to 45°C)
Humidity:	20 to 80% relative, non-condensing
Country of Origin:	Mexico

†Windows 11 supplied with units shipped after October 2024. \*DP to HDMI adapters included.

## Ordering Information Scheme

Model	Mounting Type	HDD Storage	Model Number
Workstation preloaded with ViconNet Nucleus server software; no data drives	Small Form Factor	None	NEWA-SF000D-N00

### Workstation: Small Form Factor Model

Includes five year NBD onsite KYHD (Keep Your Hard Drive) warranty with UL/FCC/CE and other required certifications.

Model Name	Storage
Intel i7 System	
NEWA-SF000D-N00	No storage

### Dimensional Drawing

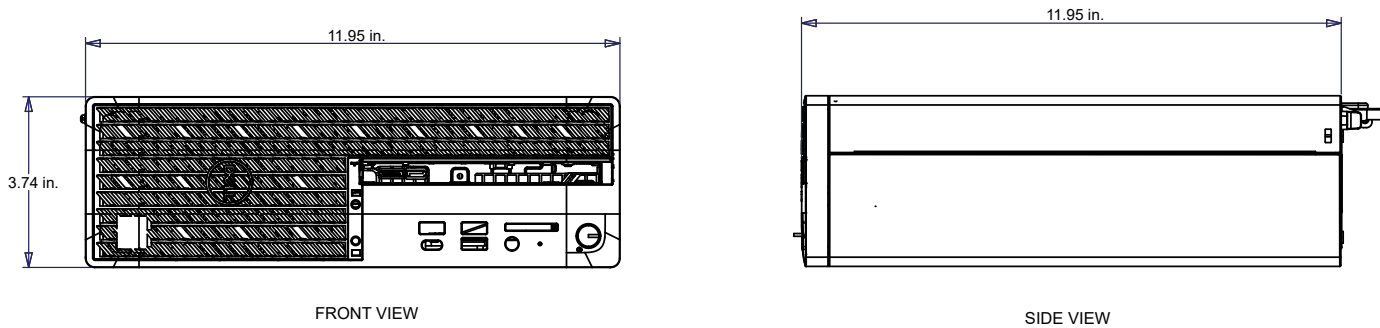

### Front and Rear Panel Controls and Connectors\*

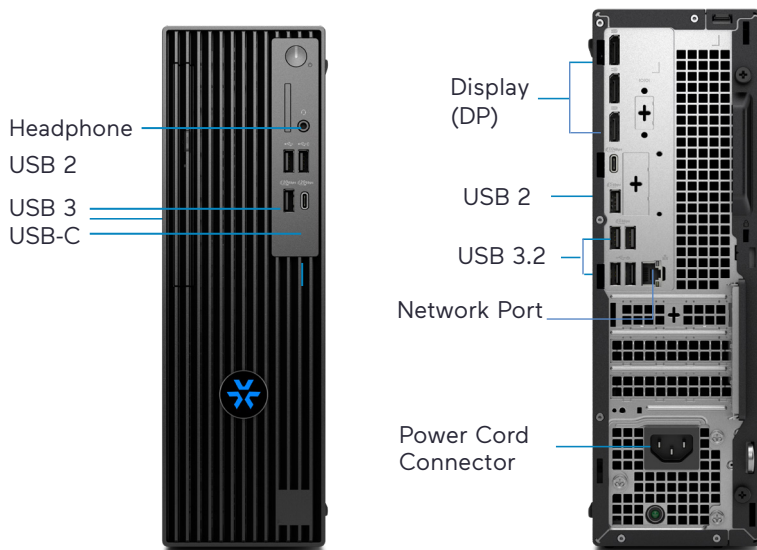

\*These drawings are for reference only. The actual video and networking ports may differ but will be similar.

Data Sheet Number: V225-31-03  
 Vicon Data Sheet Number: 8009-7225-31-03

Intel and Core are trademarks or registered trademarks of Intel Corporation.  
 Microsoft and Windows are registered trademarks of Microsoft Corporation.  
 Nvidia is a registered trademark of NVIDIA Corporation.

Specifications subject to change without notice.  
 Vicon, ViconNet and their logos are registered trademarks of Vicon Industries Inc.  
 Copyright © 2025 Vicon Industries Inc. All rights reserved.